

Carbon Monoxide Detector

E2610-CO

User Manual



Table of contents

Carbon Monoxide	3
Specifications	4
Product description	5
Safety requirements	5
Operating conditions	5
Installation guidelines	6
Connections	7
Operation	9
Maintenance	9
Calibration	9
Delivery set	10
Order code for E2610-CO options	10
Warranty	11
Manufacturer contacts	11

Carbon Monoxide

A Colorless, odorless, and tasteless gas that is highly toxic. Carbon monoxide is formed as a result of incomplete combustion of carbon-containing compounds, e.g. while operating a furnace, an oven, or an engine when there is a limited supply of air.

Synonyms: Carbonous oxide, Carbon (II) oxide, Flue gas, Monoxide

Chemical formula		CO
Molar weight		28
Relative gas density (to air)		0,97
Conversion		1 ppm= 1.15 mg/m ³
Boiling point		-191.5 °C
Low explosive limit (LEL), % vol. in air		12.5
Upper explosive limit (UEL), % vol. in air		74
Odor		odorless
Hazards		Highly toxic. Mild poisoning causes lightheadedness, confusion, headache, dizziness, and flu-like effects. Larger exposures can lead to toxicity of the CNS and heart, and death. After acute poisoning, long-term problems may occur. CO also has negative effects on a baby if exposed during pregnancy. Chronic exposure to low levels can lead to depression, confusion, and memory loss.
Exposure limits (ACGIH)	TWA	40 mg/m ³ /35 ppm
	STEL	1380 mg/m ³ /1200 ppm

Conversion of ppm to mg/m³ is calculated for 25°C and 1 atm.

Specifications

Sensor type	Electrochemical cell	
Sampling method	Diffusion	
Typical detection range	0...200 ppm	0...1000 ppm
Alarm setpoints (release-LOW-HIGH)	18 - 25 - 125 ppm	88 - 125 - 250 ppm
Resolution / digital unit	1 ppm	
Response time T90	< 30 seconds	
Sensor lifetime	> 10 years	
Calibration interval	12 months	
Power supply	24 VDC/AC ±20% (default) or 230 VAC (optional)	
Power consumption	< 2 VA	
Digital interface	UART	
Relay outputs	2 × SPDT, max 5 A, 30 VDC / 250 VAC	
Alarm	Buzzer 85 dB	
Enclosure	ABS plastic with ventilation slots, wall-mount, protection class IP20	
Dimensions	H85 × W85 × D37 mm	
CE marking	According to 2014/30/EU and 2014/35/EU, EN 50491-4-1:2012 EN 61000-6-3:2020, EN 61326-1:2013(EMC, emissions) EN 61000-6-1:2019, EN 61000-6-2:2019(EMC, Immunity) EN 60079-29-1:2016, EN 60079-29-2:2015 and EN 60079-29-3:2014	
Operating conditions	-20...50°C, 15...90% RH without condensation, 800...1200 mbar; Non-ATEX-rated areas Avoid strong mechanical shock, vibrations or EMI Avoid exposure to corrosive gases NOTE! The sensor may exhibit sensitivity to acetylene, ethylene, hydrogen, and nitric oxide.	

Product description

E2610 series gas detectors are compact and easy-to-use instruments. The devices utilize novel fully calibrated and temperature compensated gas sensors with excellent repeatability, stability, and long lifetime.

Two relays with switch-over contact may be used for remote signaling or ventilation control. Flashing LED and an internal buzzer give alarms at two setpoints.

Safety requirements

Misuse will impair the protection of the product. Always adhere to the safety provisions applicable in the country of use.

Do not perform any maintenance operation with the power on. Do not let water or foreign objects inside the device.

Removal of the PCB from the enclosure voids the warranty. Do not touch the electronic components directly, as they are sensitive to static electricity.

Connection diagrams can be found in the connections section. The device might not perform correctly or be damaged if the wrong power supply is connected.

External circuits connected to the equipment should have sufficient insulation rating according to the environmental conditions and equipment power.

A disconnecting device that is marked as such and easily accessible should be included in the installation of this product.

Operating conditions

The device should be used both in a non-hazardous indoor area and in a basic electromagnetic environment, where the latter is defined in EN 61326-1. Avoid strong mechanical shock and vibrations. Avoid corrosive atmosphere and areas highly contaminated with dust, oil mist, etc. Keep the instrument away from direct sunlight. A sudden temperature or humidity change might affect the sensitivity of the sensor.

Installation guidelines

There are no precise rules or standards to follow when installing gas detectors. The following points must be taken into account:

- Application (the instrument is intended for leakage control.)
- Properties of the space under investigation (room geometry, direction, and velocity of airflows, etc.),
- Carbon monoxide has practically the same density as air and spreads evenly in the room. Install the sensor in proximity to possible leakage or generation source, taking into consideration the temperature of the gas, the air currents in the room, etc.
- The device should be accessible for maintenance and repair.

The aforementioned conditions above will affect the coverage area of the device. however, the coverage area for a detector is usually between 2.5 to 5 meters radius.

For early leakage detection install the sensor as close as possible to the potential leakage sources (flanges, valves, pressure reducers, pumps, etc.), taking into consideration other points listed above.

For general area monitoring without definite leakage sources, the detector should be distributed evenly in the room.

Do not locate the detector close to ventilation openings and strong air currents. Avoid the areas without air circulation (corners, niches) as well.

For personal safety control, the detectors are installed in the breathing zone (at the height of the head of people or animals). The recommended sensor position is vertical, pointing downwards.

Connections

1. Detach the base of the enclosure by gently pulling along four guiding pins.
2. Attach the base to the wall with two screws. (see drawings below).

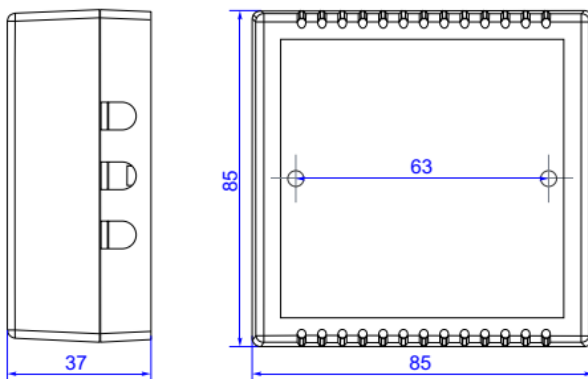

3. Use rounded cutouts on the side of the base to let in the cables from the power supply and of the external devices as shown below.

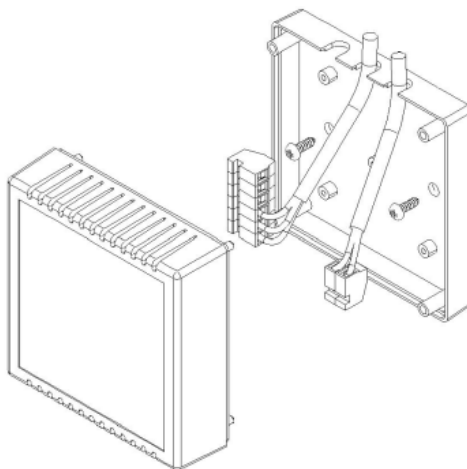

For easier connection, terminal blocks of E2610 series devices are removable. To dismount the terminal block, pull it off from the PCB. Connect the power terminals N and L to the 24 V power source if you are using detector version -24 or to 230 V AC mains if you are using detector version -230 (see diagram below).

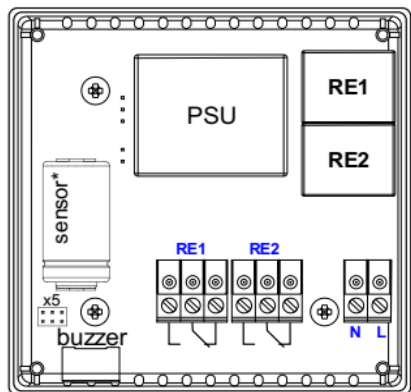

*Sensors may have different shape and/or size

Terminals	
RE1 NO	Relay 1, normally open terminal
RE1 COM	Relay 1, common terminal
RE1 NC	Relay 1, normally closed terminal
RE2 NO	Relay 2, normally open terminal
RE2 COM	Relay 2, common terminal
RE2 NC	Relay 2, normally closed terminal
L	90...265 VAC Phase (optional 24 VAC / VDC)
N	90...265 VAC Neutral (optional 24 VAC / VDC)

The terminals on the E2610 series devices are suitable for a wide range of wires with cross-section 0,2...1,5 mm². We recommend to strip the wire end by 5...6 mm and tin it, or to use the wire end sleeves. To connect the wire, loosen the screw, insert the wire end into the terminal hole and tighten the screw.

Connect external devices. Relay switch-over outputs may be used to control directly 24 V or 230 V (for versions -24 and -230 respectively) powered alarm sirens, ventilation fans, shut-off valves, or other actuators. Attach terminal blocks to the board.

4. Push enclosure to the base.

Operation

Turn on the power. During the first ca.60 seconds after powering on E2610 performs a warming-up and self-diagnostic routine, indicated by the flashing of each LED. The upper dual-color LED remains continuously green in normal operation and blinks red in case of device or sensor fault.

The warm-up time depends on the sensor type, unpowered period, and atmosphere. During the first 30 seconds after powering on you may select the automatic or manual mode of alarm release. By shortly (< 2 s) pressing the button on the device's front panel you enable the automatic mode, by pressing the button for 2...10 s – manual mode. The activation of the automatic mode is followed by a single LED blinking and acoustic signal. If manual mode is activated, the double acoustic and light signal follows.

If the gas concentration exceeds the LOW alarm setpoint, the bottom red LED starts flashing at a rate of 1 Hz, and the relay RE1 switches over. The first alarm stops automatically if the gas concentration drops below 70% of the LOW alarm setpoint.

If the gas level exceeds the HIGH alarm setpoint, the bottom red LED starts flashing and the buzzer starts beeping at a rate of 2 Hz, and also the relay RE2 switches over. Depending on the selected release mode, the HIGH alarm stops automatically or can be stopped by pressing the button, on condition that the gas level has dropped below 70% of the LOW alarm setpoint.

Beyond the warm-up period, holding down the button for 2...10 seconds and releasing causes E2610 to reset and perform the self-diagnostic routine for testing purposes. When holding the button down for over 10 seconds, E2610 imitates the reaching of the HIGH setpoint with the respective light and sound indication and switching over the relays.

Maintenance

Do not perform any maintenance operation with the power on.

Clean the device with a soft damp cloth. Do not use any abrasive cleaning agents. Do not immerse the device in water or any cleaning media.

Calibration

E2610-CO detectors have been calibrated by the Manufacturer with standard gas mixtures before delivery. Provided that the sensor is used under moderate conditions, field recalibration is recommended every 12 months. Please contact your dealer for more information.

Delivery set

- Carbon Monoxide Detector E2610-CO
- Mounting accessories:
 - 2 screws and 2 plastic dowel plugs

Order code for E2610-CO options

E2610 options	Order code
Integrated 90...265 V mains power supply module	E2610-CO-230
Integrated 24 VAC power supply module	E2610-CO-24VAC

Warranty

This product is warranted to be free from defects in material and workmanship for a period of one year from the date of the original sale. During this warranty period, the Manufacturer will, at its option, either repair or replace a product that proves to be defective. This warranty is void if the product has been operated in conditions outside ranges specified by the Manufacturer or damaged by customer error or negligence or if there has been an unauthorized modification.

Manufacturer contacts

Evikon MCI OÜ

Teaduspargi 9, Tartu

50411 Estonia

info@evikon.eu

www.evikon.eu

